



YOSHIMURA

RESEARCH&DEVELOPMENT OF AMERICA, INC.

5420 DANIELS STREET STE A, CHINO CA., 91710 · (800)634-9166 · (909)628-4722 · FACSIMILE (909)591-2198

www.yoshimura-rd.com

Signature Series

Kawasaki Z1000

14151E0220 (CF)

14151E0520 (SS)

R-77 Slip-On Exhaust System



This product is 50-state legal and complies with Federal and State regulations. Any attempts to modify this product will render it non-compliant with Federal law and void warranty. If modified, the vehicle can no longer be used on public roads and can only be used for off-highway closed course competition. In the state of California, it is illegal to modify the emission control system, which includes the fuel injection system of any vehicle.



14151E0(220,520)

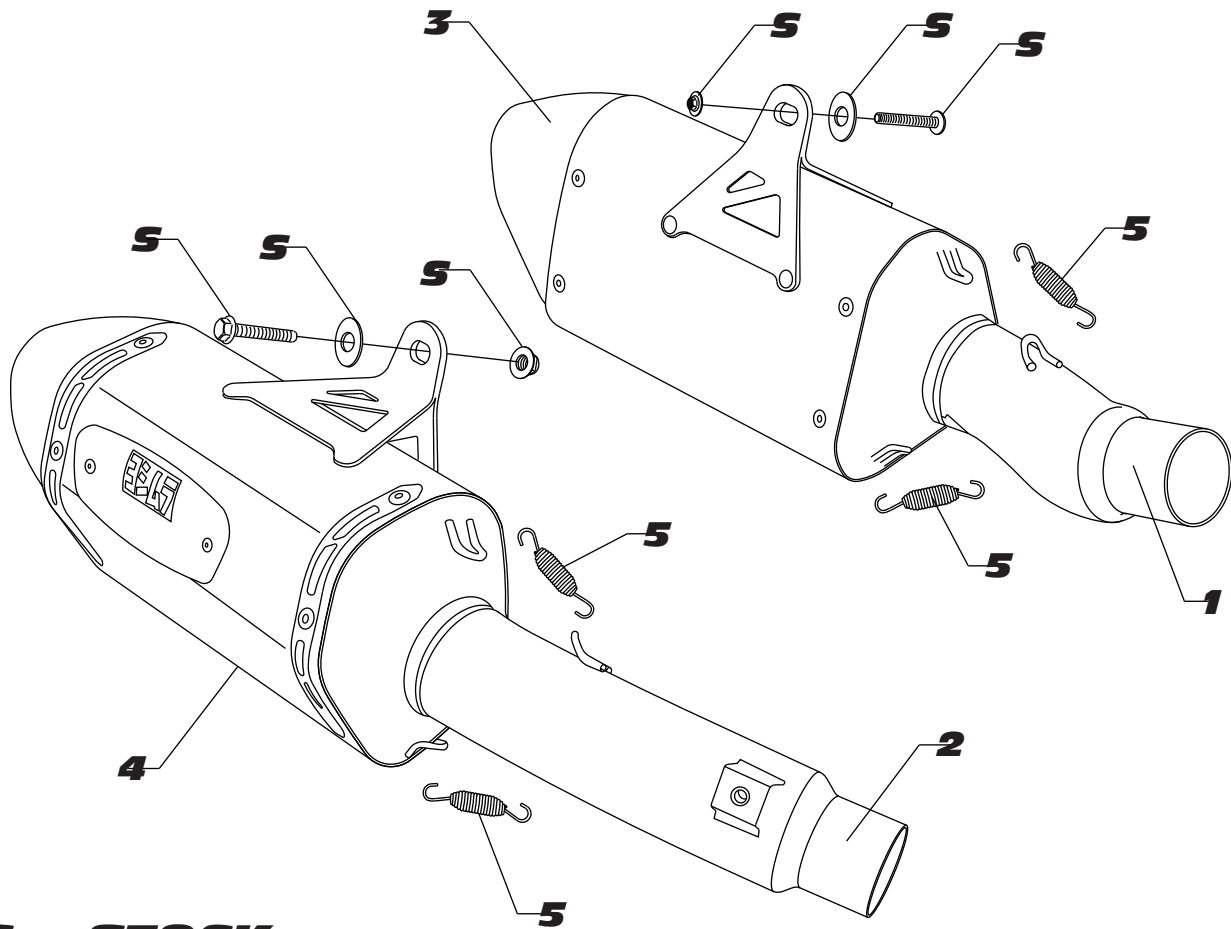

S = STOCK

Parts Diagram

NO.	DESCRIPTION	QTY	PART #
1	Yoshimura Left Stainless Steel Tailpipe	1	1412-426-00
2	Yoshimura Right Stainless Steel Tailpipe	1	1412-427-00
3	R-77 Left Muffler Assembly		
	Carbon Fiber Sleeve with Carbon Fiber Endcap	1	****
	Stainless Steel Sleeve with Carbon Fiber Endcap		****
4	R-77 Right Muffler Assembly		
	Carbon Fiber Sleeve with Carbon Fiber Endcap	1	****
	Stainless Steel Sleeve with Carbon Fiber Endcap		****
5	Small Muffer Spring	4	RACE-SPX-1
**	Yoshimura Spring Puller Tool	1	ST-200
**	Yoshimura Vinyl Sticker	1	17029

**** Signature Series muffler replacement part number unavailable. Repair or replacement of Signature Series exhaust systems is only available directly through Yoshimura R&D of America, Inc.

Caution: Exhaust system can be extremely hot. Let motorcycle cool down before beginning installation. Always wear hand and eye protection and take precautionary measures to avoid injury.

Note: Read through all instructions before beginning installation.

Tools Needed:

Metric Socket Set
Metric Combination Wrench Set
Metric Allen Wrench Set
Torque Wrench

Installation Steps:

1. Disconnect Exhaust Valve Cable

- Remove passenger seat to expose two bolts holding rider seat.
- Remove rider seat to expose exhaust valve servo (Fig. 1).
- Remove metal clip securing cables.
- Disconnect cables from servo (servo will be left with no cables connected).
- No other components are required to prevent the check engine light from turning on.
- Re-install rider seat and passenger seat.

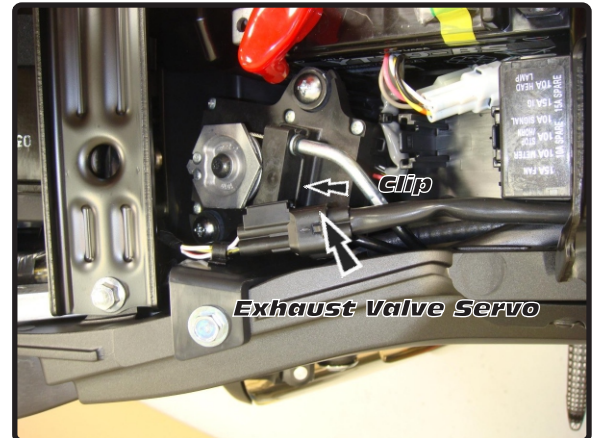

Fig. 1

2. Remove OEM Exhaust System

- Remove right side muffler heatshield bolt and heatshield. (Fig. 2).
- Loosen right side tailpipe clamp (Fig. 2).
- Remove right side muffler hanger bolt (Fig. 2).
- Remove muffler, taking care to slowly route the disconnected exhaust servo cable through the inside of the frame to remove.
- Loosen left side tailpipe clamp (Fig. 3).
- Remove left side muffler hanger bolt (Fig. 3).

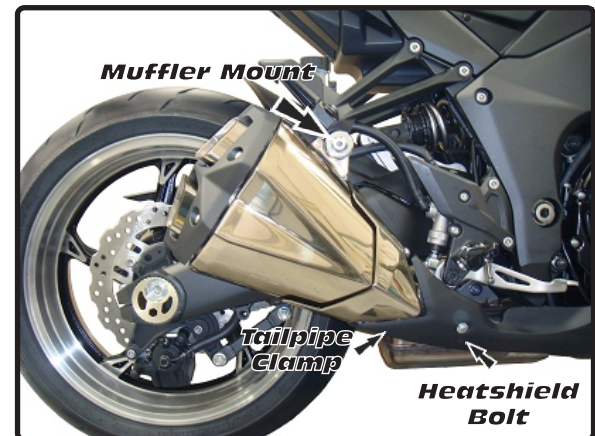

Fig. 2

NOTE: Remove OEM gaskets from stock muffler. OEM gaskets are to be reused on the Yoshimura exhaust system. If the gaskets are damaged or unusable, please source them from your local dealer using the following part number: 11061-0240.

3. Install Yoshimura Exhaust system

- Install OEM gasket onto Yoshimura tailpipe inlet.
- Insert right Yoshimura tailpipe and muffler assembly into right OEM exhaust header outlet.
- Using OEM muffler hanger hardware, secure Yoshimura muffler hanger to right passenger peg. (Fig. 5)
- Tighten muffler hanger and clamp to 18 ft-lbs (25 N-m).

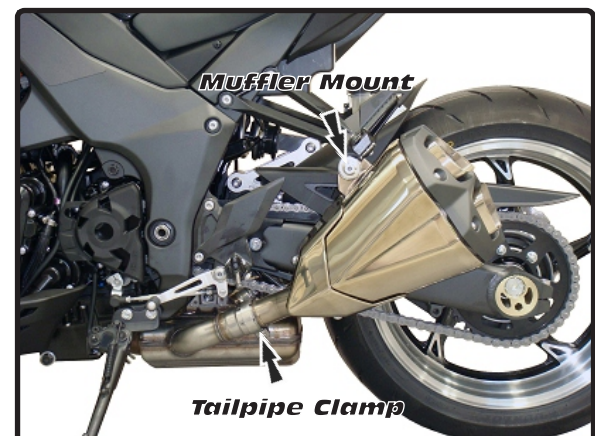

Fig. 3

3. Install Yoshimura Exhaust System (con't)

- Install OEM heatshield using OEM heatshield bolt.
- Tighten heatshield bolt to 7 ft-lbs (10 N-m).
- Install OEM gasket on left tailpipe.
- Insert left Yoshimura tailpipe and muffler assembly into left header outlet
- Using OEM muffler hanger hardware, secure Yoshimura muffler hanger to left passenger peg. (Fig. 6)
- Tighten muffler hanger and clamp to 18 ft-lbs (25 N-m).

4.. Check for proper clearance between new exhaust system and rear suspension (i.e. tire, swing-arm, brake, rear shock etc).

Adjustment of tailpipe and/or muffler may be necessary to achieve desired fit.

If any problem is found, please carefully follow through the installation steps again. If problem still persists, please call Yoshimura technical department at (800) 634-9166 / in CA (909) 628-4722 .

NOTE: *After starting the vehicle, it is normal for a new exhaust system and muffler to emit smoke until oil residue burns off.*

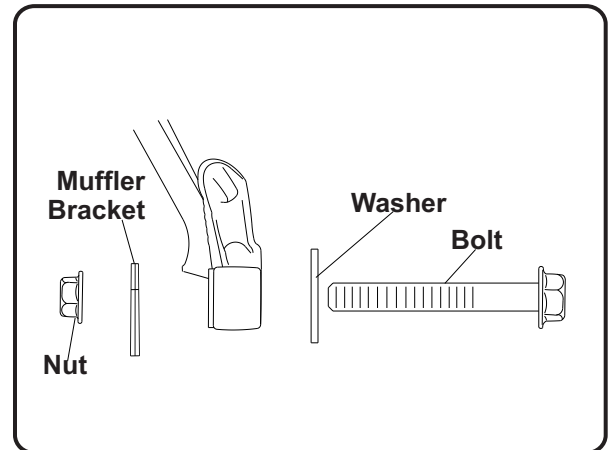
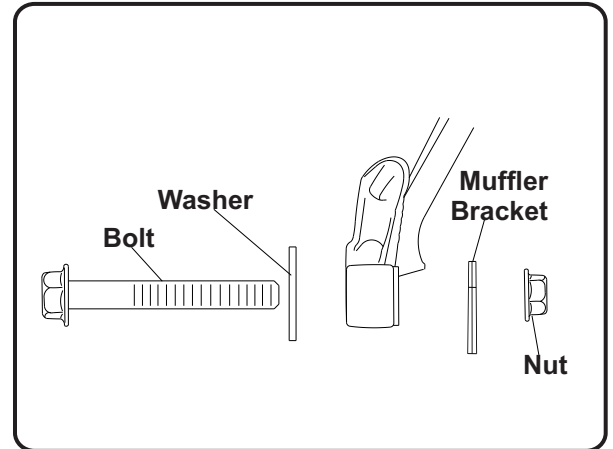
**Fig. 5****Fig. 6**

NOISE EMISSION WARRANTY

Yoshimura warrants that this exhaust system, at time of sale, meets all applicable U.S. E.P.A. Federal noise standards. This warranty extends to the first person who buys this exhaust system for purposes other than resale, and to all subsequent buyers. Warranty claims should be directed to Yoshimura R&D of America, Inc. 5420 Daniels St. Chino, CA 91710 | Tel (800) 634-9166

TAMPERING PROHIBITION

Federal law prohibits any modification to this exhaust system which causes the motorcycle to exceed the Federal noise standard. Use of the motorcycle with such a modified exhaust system is also prohibited.

Acts likely to constitute tampering include removal or puncturing the muffler, baffles, header pipes, or any other component which conducts exhaust gases.

WARNING: This product should be checked for repair or replacement if the motorcycle noise has increased significantly through use. Otherwise, the owner may become subject to penalties under state and local ordinances.